

Twin Bar Lite

Cat. No. TBL

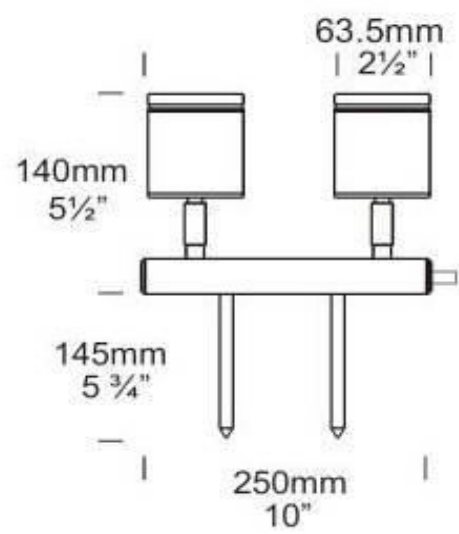

UK & European Specification

The Twin Bar Lite is ideal for wall or sign illumination using 2 x 20 watt lamps with a Light Ideas transformer. The luminaire has two individual spot lites which can be aimed in two entirely different directions. Each lite has a fully adjustable arm allowing 360 degree rotation and 0 - 90 degree elevation adjustment. The heads are mounted on a 250mm (10") bar with twin ground spikes.

This luminaire is machined from a choice of 10mm thick aluminium with a UV stable powder coated finish, solid copper or 316 stainless steel with a clear, tempered, flush glass lens and high temperature silicon gaskets.

Please note that a GU10 option is not available for this luminaire.

Ordering Information

Luminaire	Material/Finish	Accessories
TBL - Twin Bar Lite	BK - Black BZ - Bronze GN - Green STAR - Silver Star COP - Copper SS - 316 Stainless	CJK - Cable joint Kit LENSSTEPF - Frosted Lens GG - Glare Guard HCL - Hex Cell Louvre Adaptor /300 - 300 (12") Spike

Example: **TBL BK**

(Accessories ordered separately)

Luminaire Construction

CNC machined from one of the following metals:

High corrosion resistant 63.5mm (2½”) x 10mm (25/64”) aluminium. End cap - solid aluminium 63.5mm (2½”) rod, with chromate substrate and high UV resistant polyester powder coat

Colours Black, Bronze, Green, Silver Star.

Copper 63.5mm (2½”) x 10mm (13/32”). End cap - solid copper 63.5mm (2½”) rod.

316 Stainless Steel 9mm (11/32”). End cap - solid 316 stainless steel 63.5mm (2½”) rod.

Mounting

Spike 150mm (6”) 300mm (12”) mounted directly into the ground.

Features

Lens:
10mm (3/8”) clear ‘flush fit’ shatter resistant glass. Life Time Warranty.

Gaskets:
Silicone, iron impregnated 220°C (428°F)

Lamp Holders:
GU5.3 - 350°C (662°F) ceramic multi contact lamp holder with 250°C (480°F) teflon cables.

Accessories:
Cable Joint Kit (Cat. CJK150)
Frosted Lens (Cat. LENSSTEPF).
Glare Guard (Cat. GG).
Hex Cell Louvre Adaptor (Cat. HCL).
Ground Spike 300mm (12”) (Cat. /300).

Swivels:
Aluminium and Copper luminaires 360° rotation and 0 - 90° elevation, solid brass with anti rust spring.
Stainless Steel luminaires - 360° rotation and 0 - 90° elevation, full stainless steel construction.

Standards

IP66
UL1838

Luminaire Weight

Alum 1.060kg (2lb 5oz)
Cop 2.840kg (6lb 4oz)
SS 2.420kg (5lb 5oz)

Power Supply

HUNZA™ Inground or HUNZA™ Wall Mount Transformer: not included.

Supplied With

MR16 GU5.3 - 2 x 20, 35 or 50 watt lamps max.

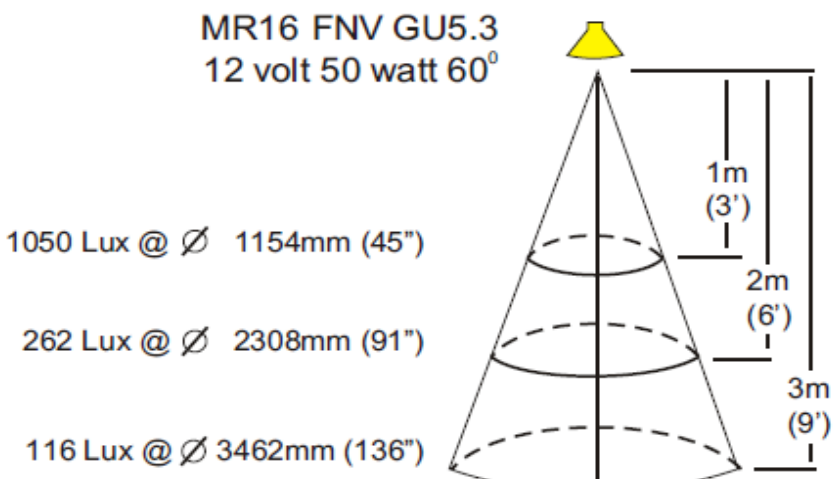
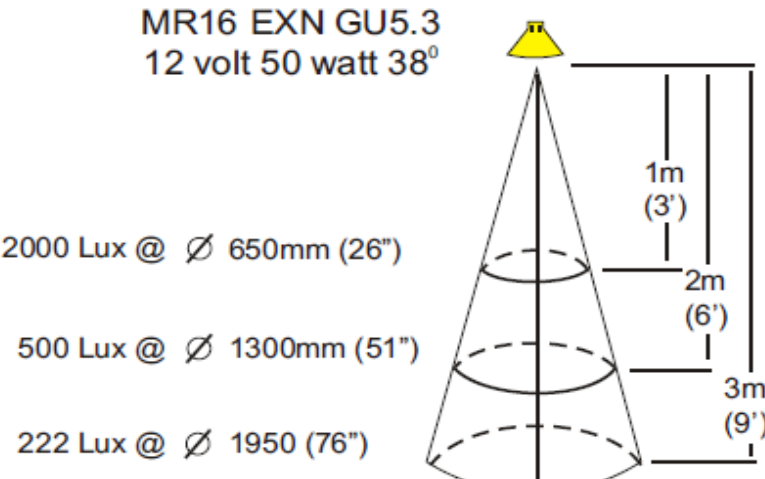
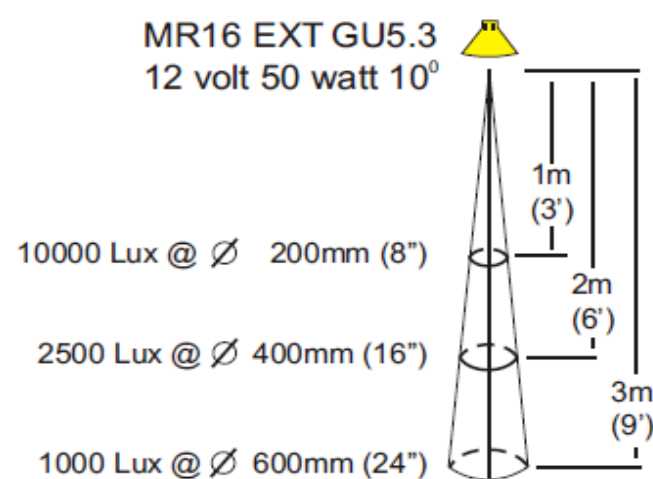
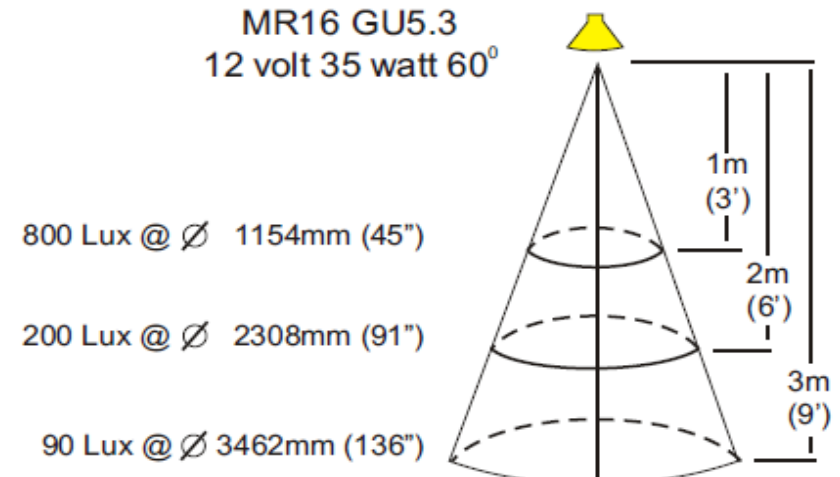
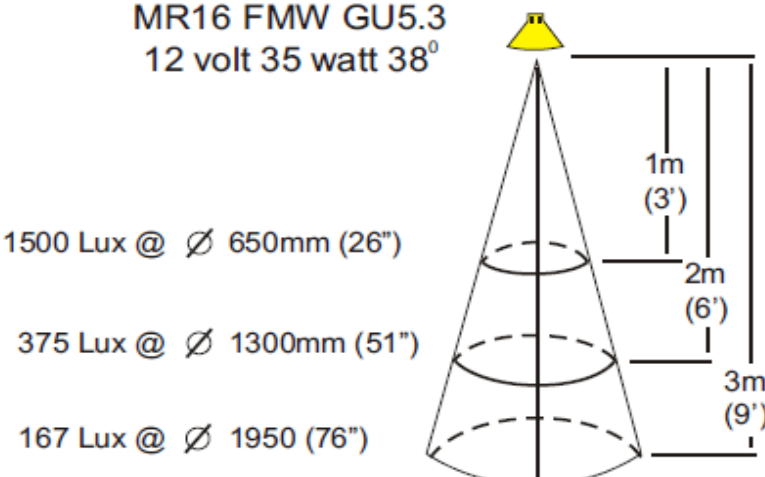
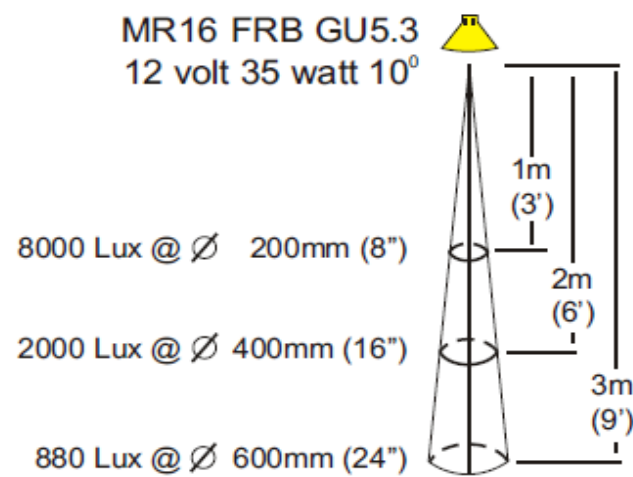
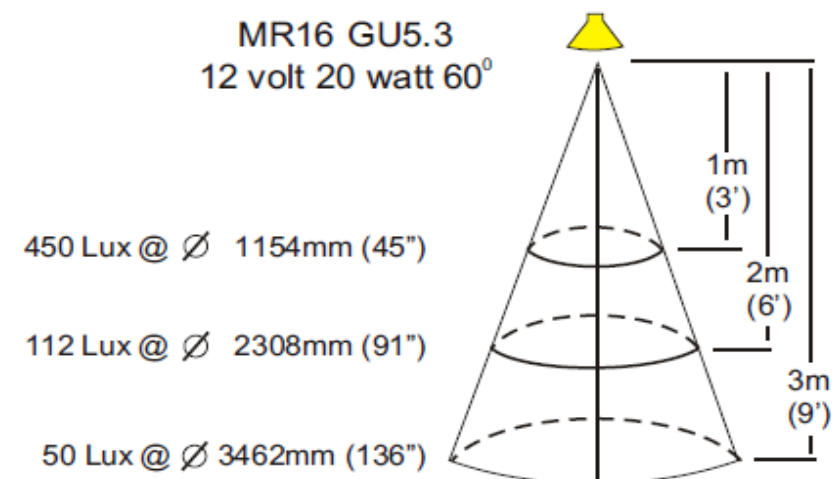
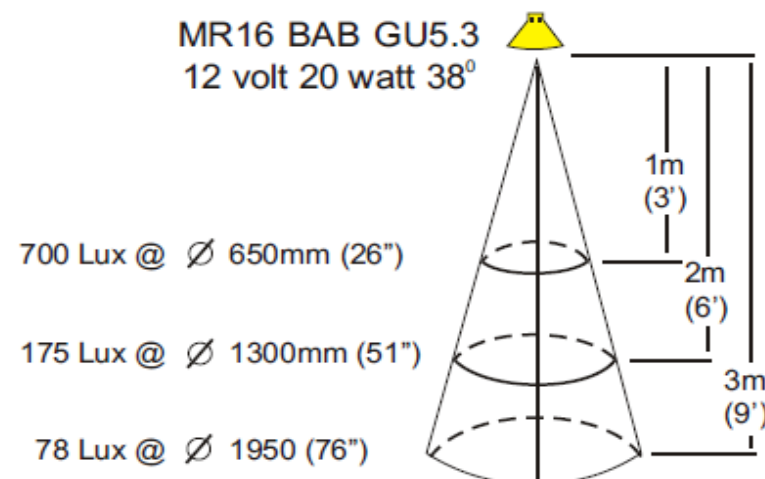
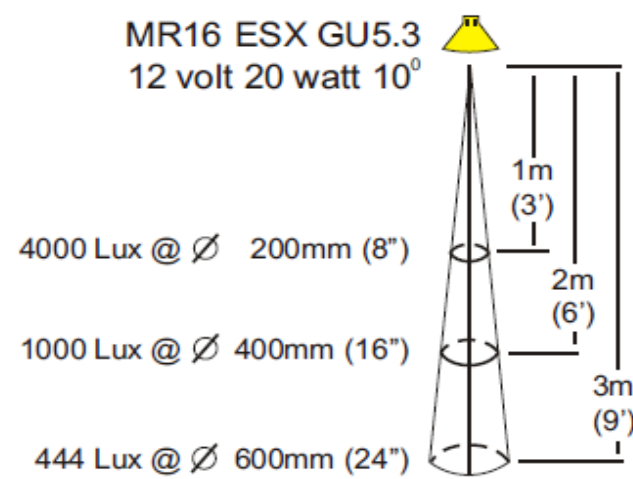

	<p>HUNZA FACTORY 130 Felton Mathew Ave Saint Johns Auckland 1072 New Zealand</p>	<p>Ph: 64-9-528 9471 Fax: 64-9-528 9361 hunza@hunza.co.nz www.hunza.co.nz</p>	<p>INTERNATIONAL CONTACTS: www.hunza.co.nz/contacts.php</p> <p><small>Specifications may change without notice. Manufactured in New Zealand. © 2014 Hunza Holdings Ltd.</small></p>
--	---	---	--